

**TOORX**  
FITNESS IN MOTION

# INSTRUCTION



# SRX60S



Cod : GRLDTOORXSRX60S

Rev : 00

Ed : 09/18



# EXPLODED-VIEW & PARTS LIST :

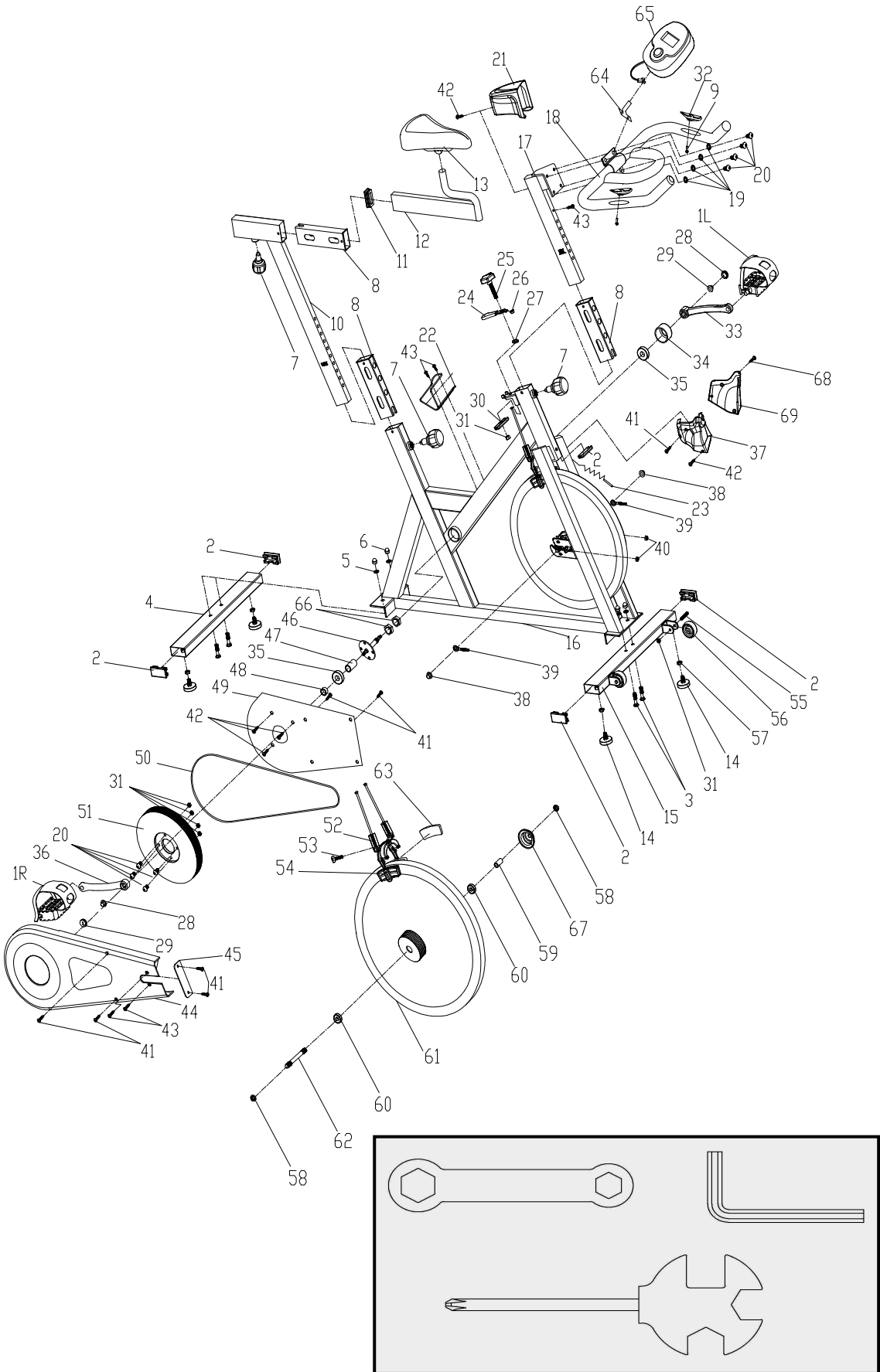

NO	NAME	QUANTITY	SPEC
1L	PEDAL L	1	JD-301 (9/16") L
1R	PEDAL R	1	JD-301 (9/16") R
2	END CAP1	5	60*30*1.5
3	CARRIAGE BOLT	4	GB/T 12-1988 M8*42
4	REAR STABILIZER	1	WELDING
5	FLAT WASHER	4	GB/T 95-2002 8
6	DOMED NUT	4	GB/T 802-1988 M8 (H=16mm)
7	SPRING ADJUSTMENT KNOB	3	φ50*82 (M16*1.5)
8	PLASTIC SLEEVE	3	53.5*23.5*1.5
9	SCREW 5	2	GB/845-85 ST4.2X25
10	VERTICAL SEAT POST	1	WELDING
11	END CAP2	1	53.5*23.5*1.5
12	SEAT POST	1	WELDING
13	SEAT	1	DD-2681
14	STOPPER	4	φ32*37/(M8X25)
15	FRONT STABILIZER	1	WELDING
16	MAIN FRAME	1	WELDING
17	HANDLEBAR POST	1	WELDING
18	HANDLE BAR	1	WELDING
19	SPRING WASHER	4	GB/T 859-1987 8
20	BOLT	8	GB/T 70.2-2000 M8*15
21	HANDLEBAR COVER	1	115*89*75 (60g)
22	BOTTLE HOLDER	1	117*85*90
23	SENSOR	1	SR-202
24	BRAKE KNOB	1	112*32*7
25	ADJUSTMENT KNOB	1	φ38*79
26	LITTLE PLASTIC RING	1	14*8*9
27	PLASTIC RING	2	φ20*φ9*3
28	FIXING NUT 1	2	GB/T 6177.2-2000 M10*1.25
29	CRANK END CAP	2	φ23*7.5
30	SHEET IRON	1	δ5
31	LOCK NUT	7	GB/T 889.1-2000 M8
32	PULSE	2	
33	LEFT CRANK	1	170*27
34	CRANK COVER	1	φ56*28

NO	NAME	QUANTITY	SPEC
35	BEARING	2	6004ZZ
36	RIGHT CRANK	1	170*27
37	RIGHT PROTECT COVER	1	156*80*174 (85g)
38	FIXING NUT 2	2	GB/T 802-1988 M12X1.25
39	FIXING BOLT	2	M6*50
40	NUT	2	GB/T 889.1-2000 M6
41	SCREW 1	15	GB/T 845-1985 ST4.2*19
42	SCREW 2	2	GB/T 15856.1-2002 ST4.2X19
43	SCREW 3	2	GB/845-85 ST4.8X13
44	OUTER CHAIN COVER	1	654*263*49 (507g)
45	LITTLE CHAIN COVER	1	108*37*3 (7g)
46	AXIS	1	φ20*162
47	LONG FIXING TUBE	1	φ25*φ20.5*41
48	SHORT FIXING TUBE	1	φ25*φ20.5*9
49	INNER CHAIN COVER	1	451*260*2 (250g)
50	BELT	1	5PK53
51	BELT WHEEL	1	φ200*24
52	BRAKE	1	2PCS 130mm
53	BOLT	1	GB/T 70.1-2000 M6*20
54	BRAKE PLASTIC	2	82*41*19
55	BOLT	2	GB/T 5780-2000 M8*40
56	WHEEL	2	φ50*23
57	NUT	4	GB/T 41-2000 M8
58	FIXING NUT 2	2	M12X1.25 H=6
59	FIXING TUBE	1	φ16*φ12.1*35
60	BEARING	2	6001ZZ
61	FLYWHEEL	1	φ453*72
62	FLYWHEEL SHAFT	1	φ12*160
63	WOOLLY BLOCK	2	78*38*6
64	COMPUTER HOLDER	1	δ2.5
65	COMPUTER	1	X-3541
66	FIXING NUT	2	27*M20*1 (5mm)
67	FLYWHEEL COVER	1	φ59*35
68	SCREW 4	1	ST2.9*9.5
69	LEFT PROTECT COVER	1	157*73*157 (85g)

# ASSEMBLY INSTRUCTION:

## 1.PREPARATION:

- A. Before assembling make sure that you will have enough space around the item.
- B. Use the present tooling for assembling.
- C. Before assembling please check whether all needed parts are available (at the above of this instruction sheet you will find an explosion drawing with all single parts (marked with numbers) which this item consists of.

## 2.ASSEMBLY INSTRUCTION:

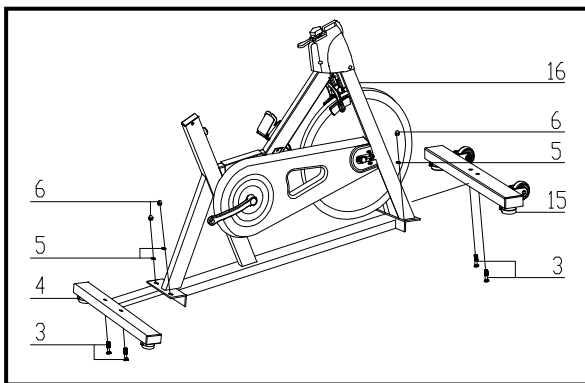

FIG.1:

Attach the Front Stabilizer (pt.15) to the Main Frame (pt.16) using two sets of Ø8 Flat Washers (pt.5), M8 Domed Nut (pt.6) and M8\*42 Carriage bolt (3). Attach the Rear Stabilizer (pt.4) to the Main Frame (pt.16) using two sets of Ø8 Flat Washers (pt.5), M8 Domed Nut (pt.6) and M8\*42 Carriage bolt (3).

FIG.1

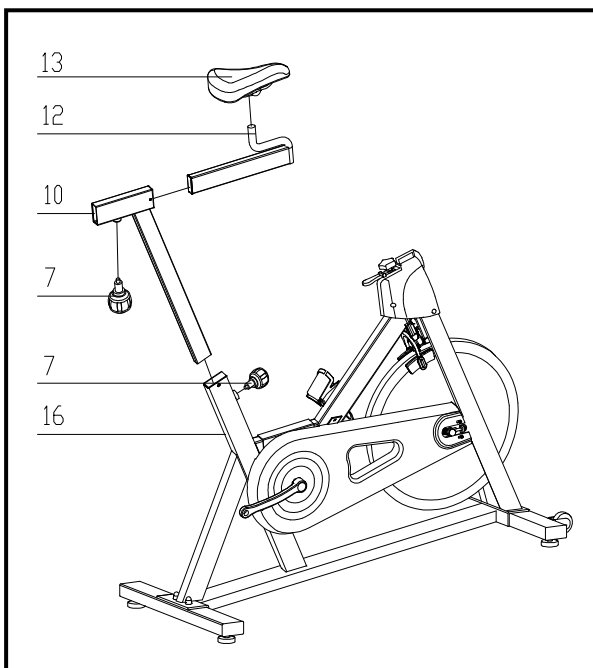
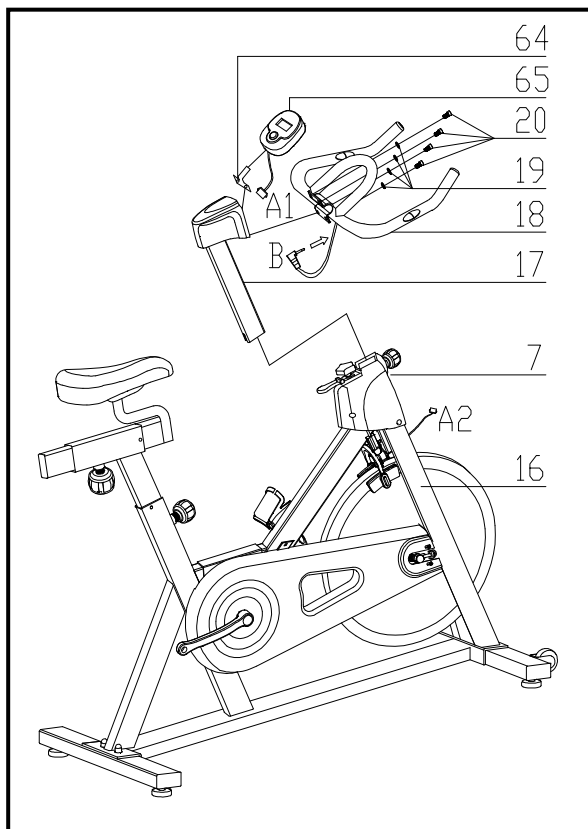

FIG.2:

Slide the Vertical Seat Post (pt.10) into the seat post housing on the main frame (pt.16). Then slide the Seat Post (pt.12) into the Vertical Seat Post (pt.10). You will have to slacken the knurled section of the Spring Adjustment Knob (pt.7) and pull the knob back and then select and align holes for the desired height. Release the knob and retighten the knurled portion.

Now fix the Seat (pt.13) to the Vertical Seat Post (pt.12) as shown, and tighten the bolts around the screws under the seat.

FIG.2



**FIG.3**

**FIG.3:**

Slide the Handlebar Post (pt.17) into the handlebar post housing on the main frame. You will have to slacken the knurled section of the Spring Adjustment Knob (pt.7) and pull the knob back and then select and align holes for the desired height. Release the knob and retighten the knurled portion.

Remove the bolts and spring washer from the Handlebar Post (pt.17), then fix the Handlebar (pt.18) with 4pcs Ø8 the Spring Washer (pt.19) and M8\*15 the Bolt (pt.20).

**ATTENTION: YOU SHOULD FIX THE HANDLEBAR TIGHTLY**

Slide the Computer (pt.65) onto the Computer Holder (pt.64) connect the plug (A1&A2), Insert the sensor cable (B) into the bushing located on the backside of the computer (65).

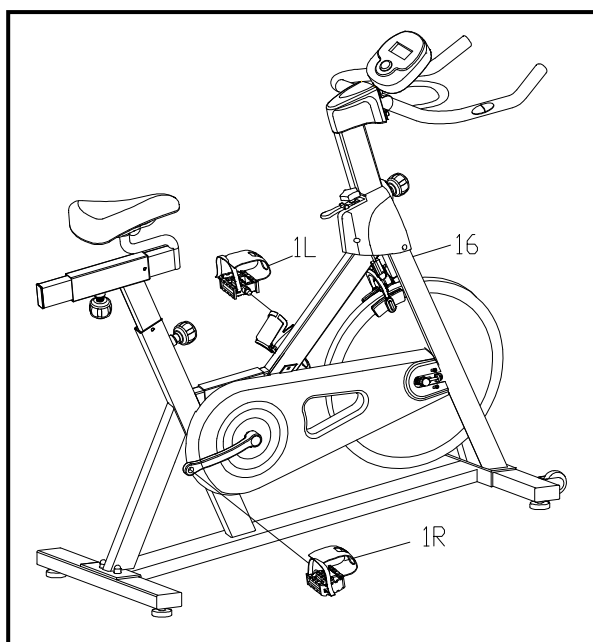

**FIG.4**

**FIG.4:**

The Pedals (pt.1 L & pt.1 R) are marked "L" and "R" - Left and Right. Connect them to their appropriate crank arms. The right crank arm is on the right- hand side of the cycle as you sit on it.

Note that the Right pedal should be threaded on clockwise and the Left pedal anticlockwise.



GARLANDO SPA  
Via Regione Piemonte, 32 - Zona Industriale D1  
15068 - Pozzolo Formigaro (AL) - Italy  
[www.toorx.it](http://www.toorx.it) - [info@toorx.it](mailto:info@toorx.it)