

TOORX
FITNESS IN MOTION

INSTRUCTION



MIRAGE C60



Cod : GRLDTOORXTRXMC6

Rev : 00

Ed : 03/21



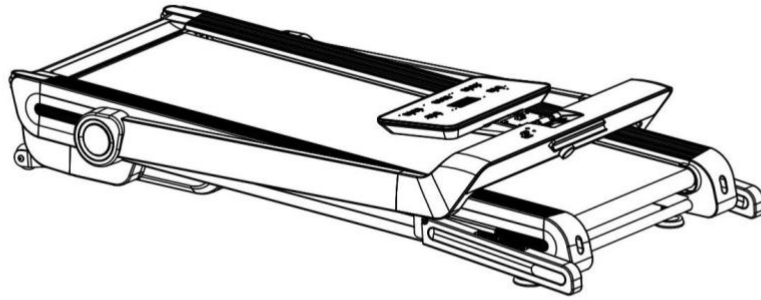

A



B09



C39



C55



D09

NO.	DES.	Specification	Nos.	NO.	DES.	Specification	Nos.
A	Main frame		1	C55	Silicone oil		1
B09	6# Allen wrench		1	D09	Power wire		1
C39	Safety key set		1				

B-1

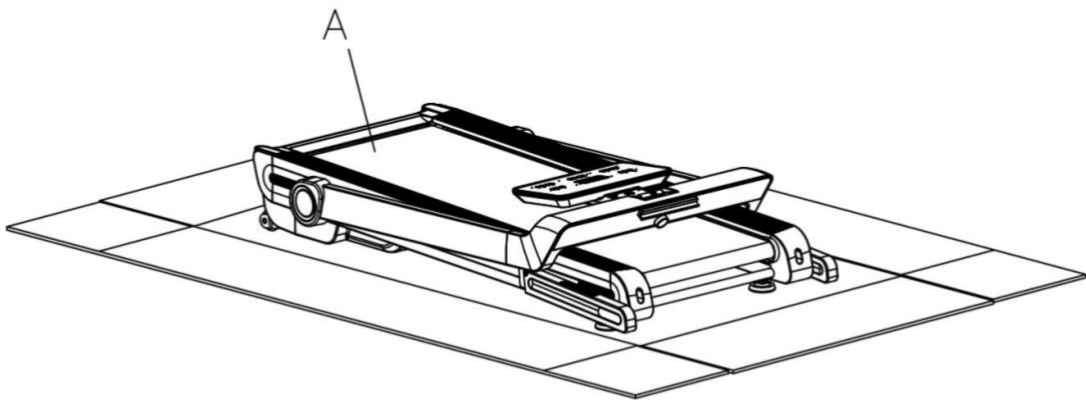

B-2

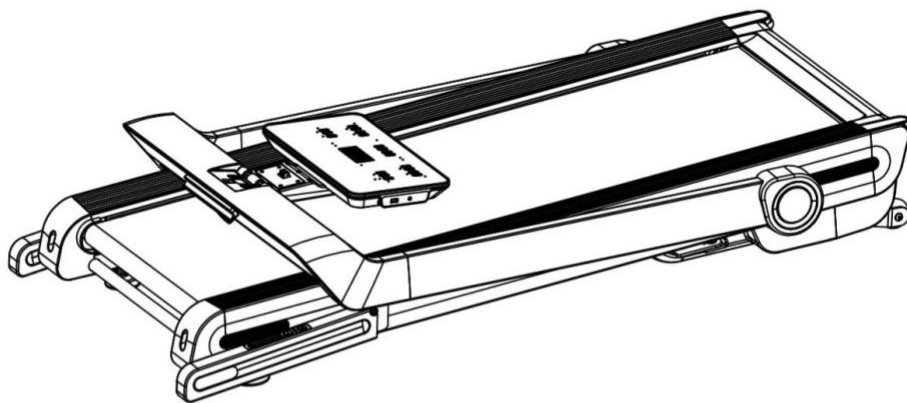

B-3

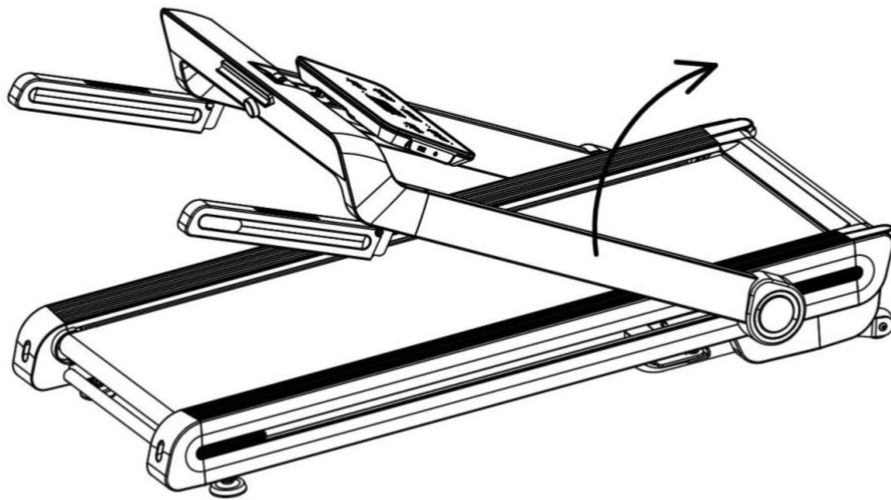

B-4

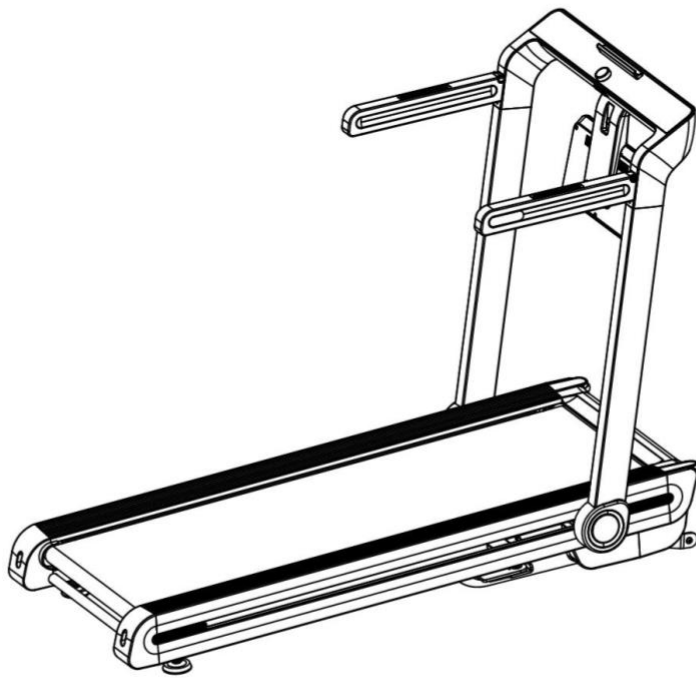
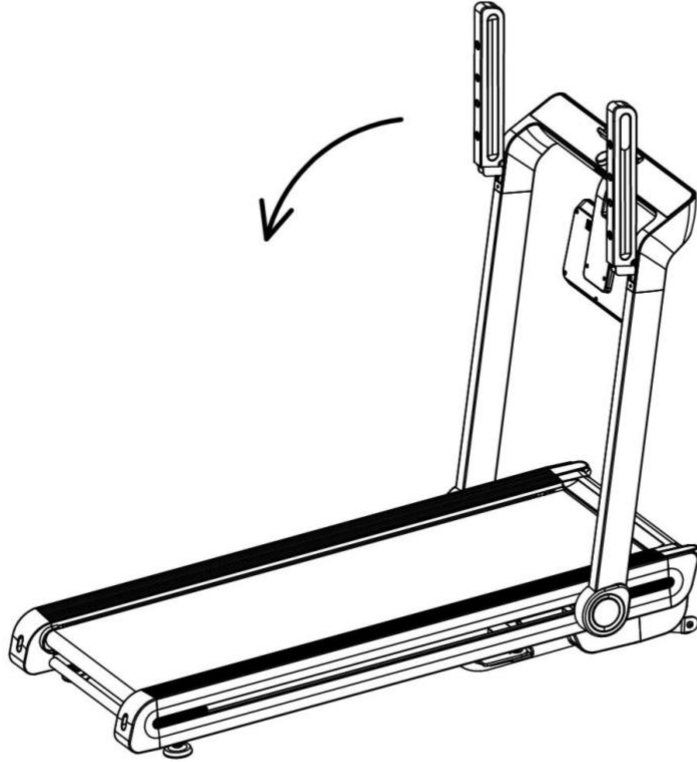

B-5

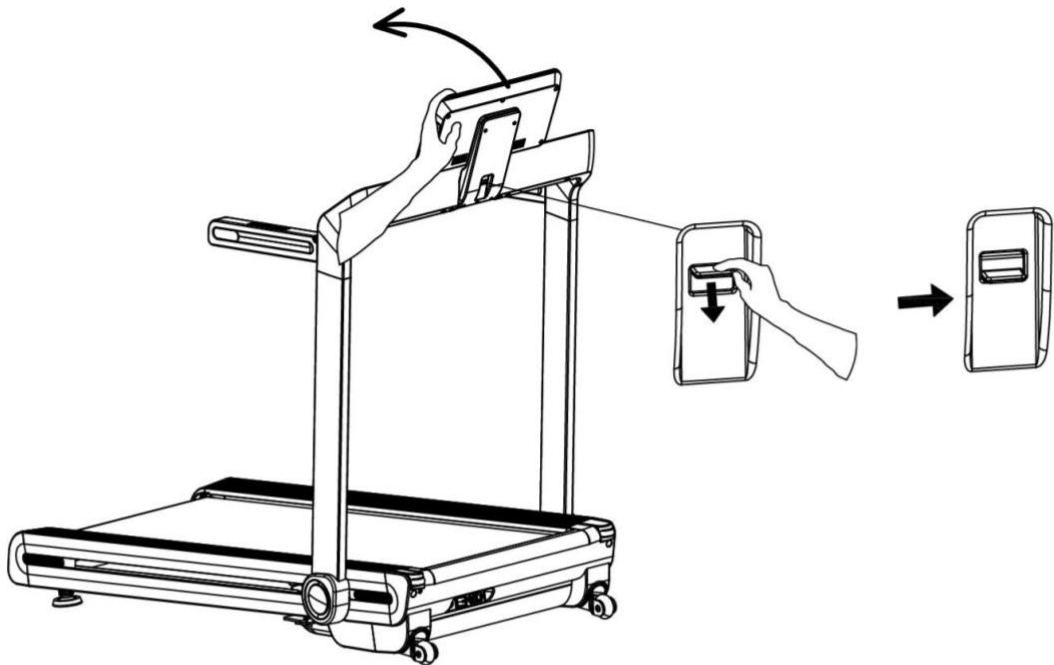
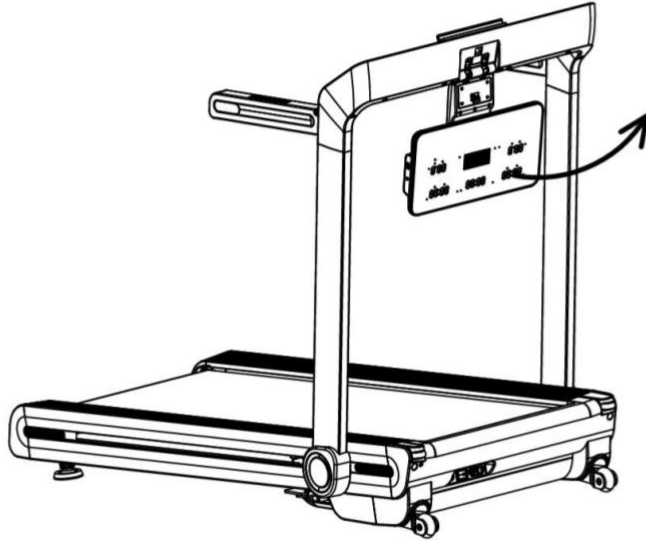

B-6

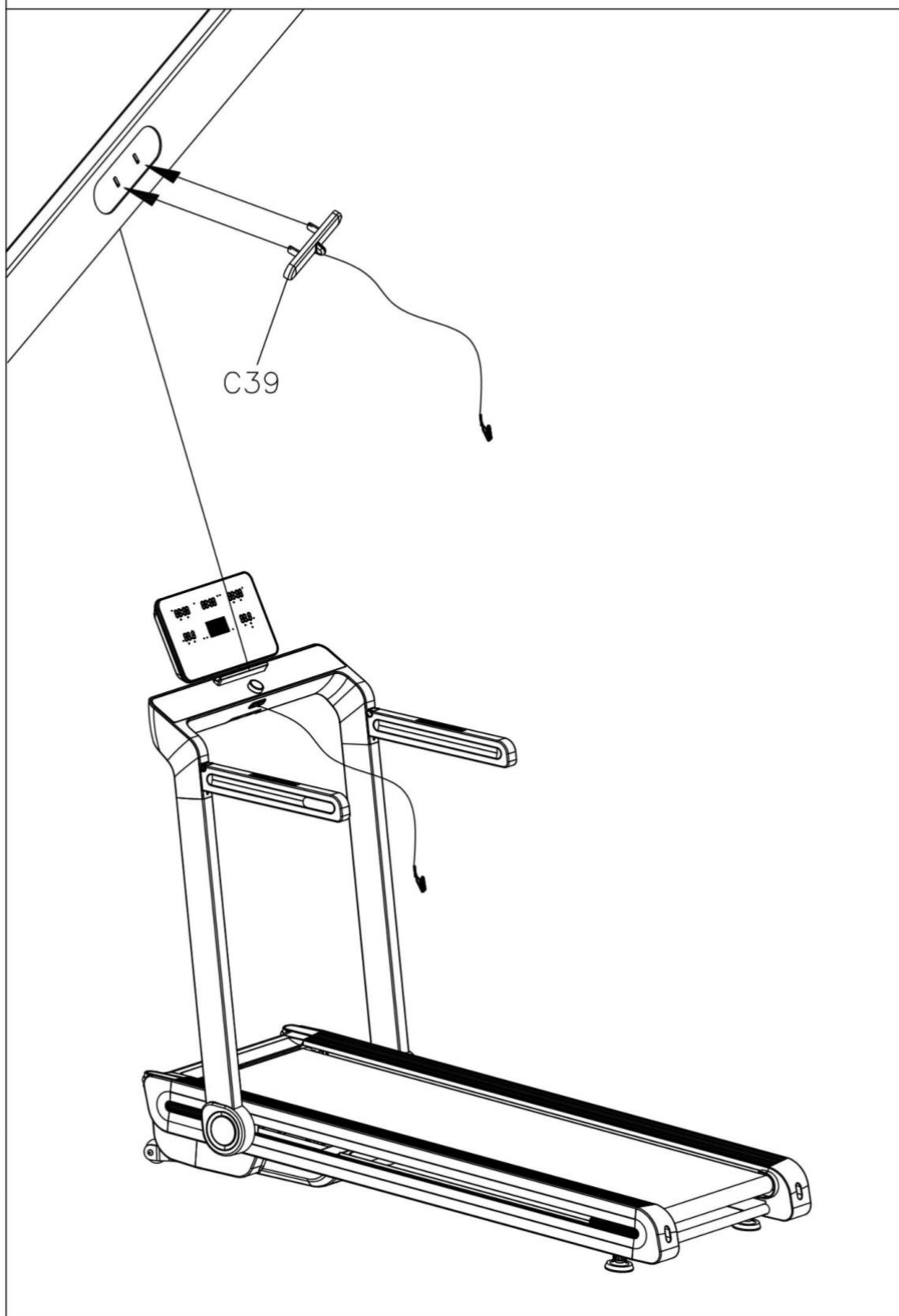

B-7

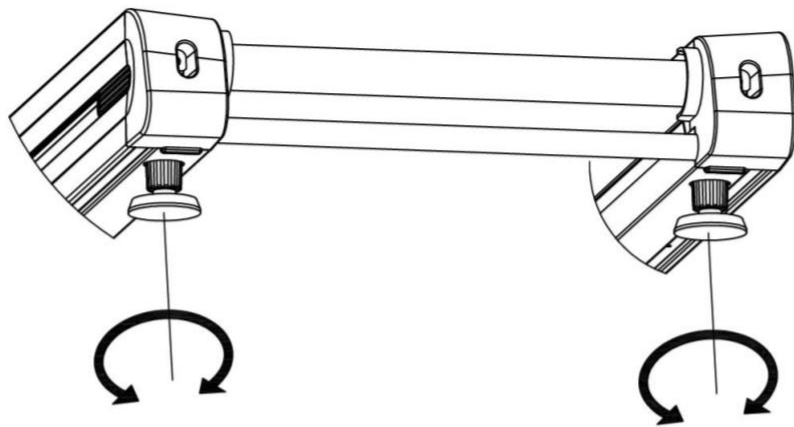
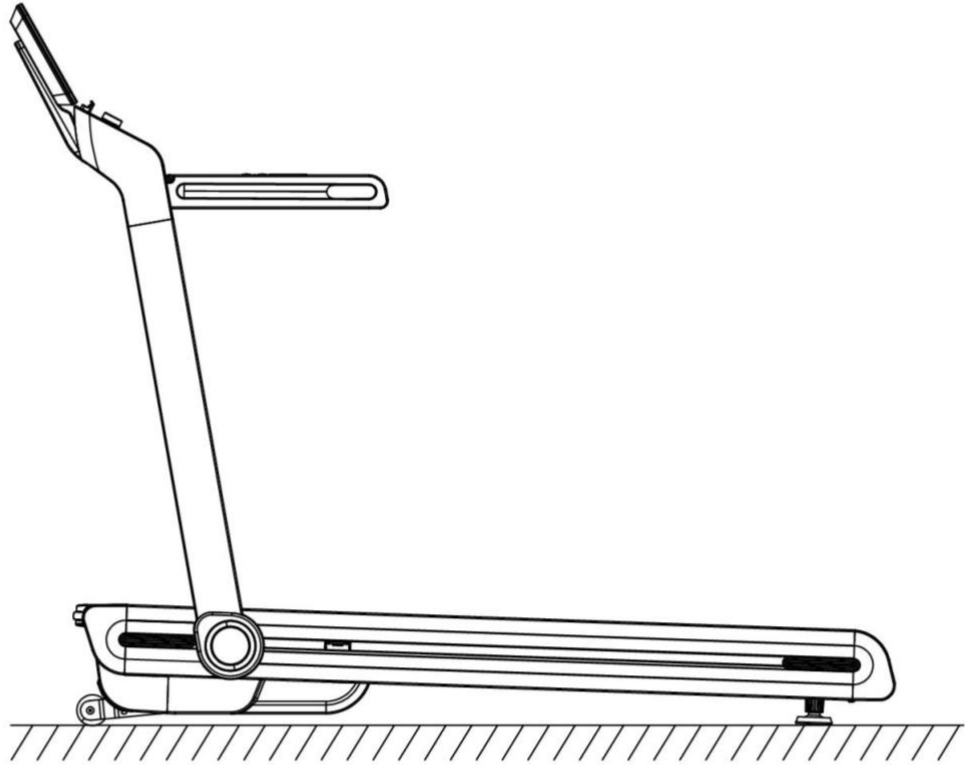

B-8

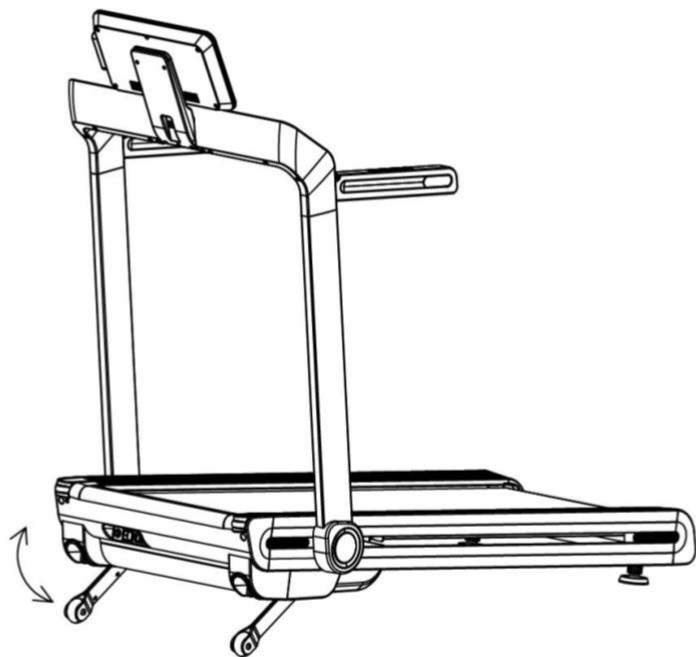
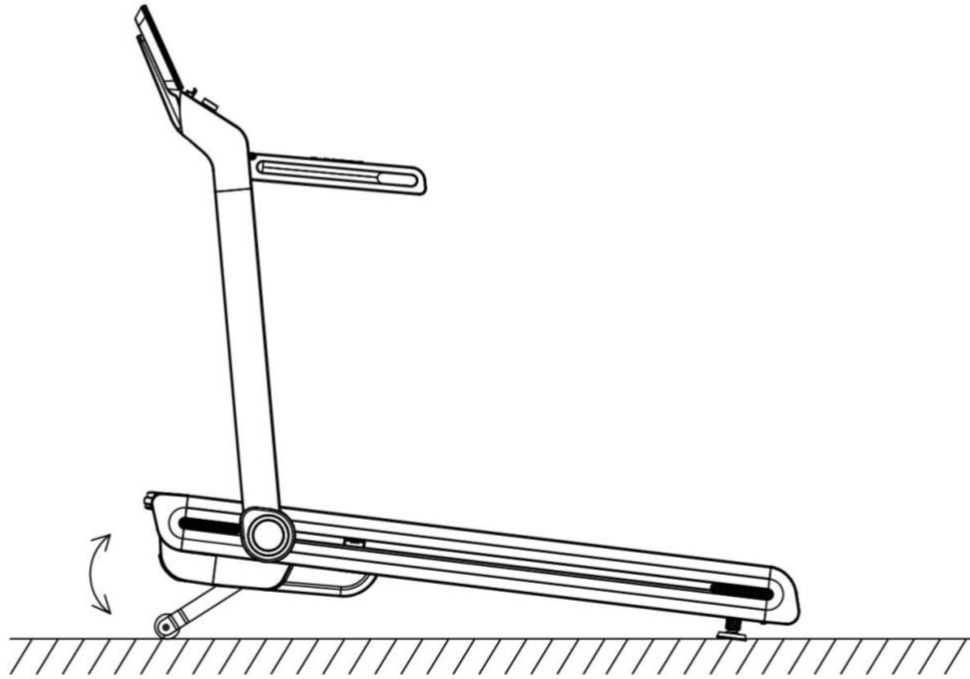

LATERAL FOLDING

C-1

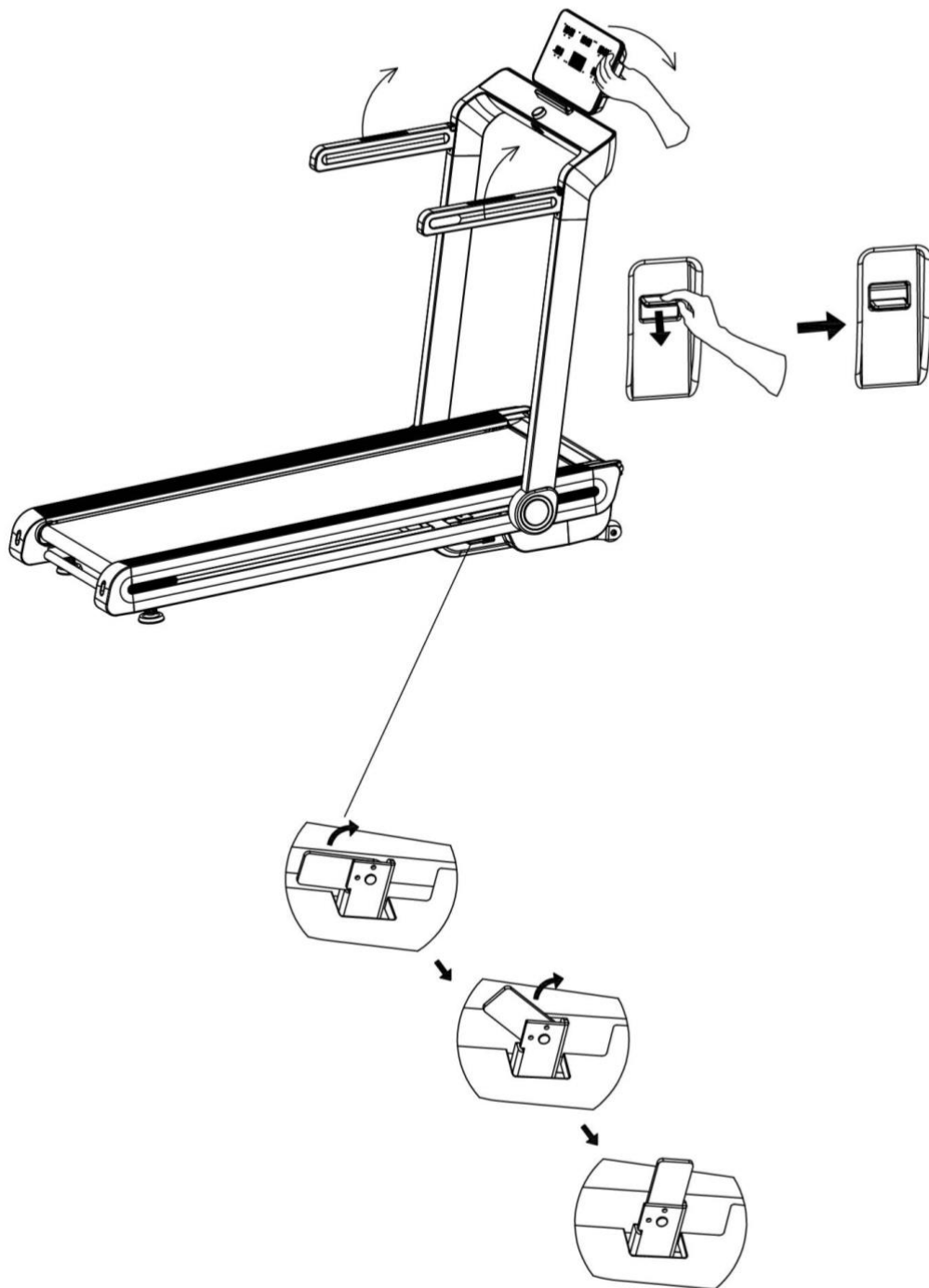

C-2

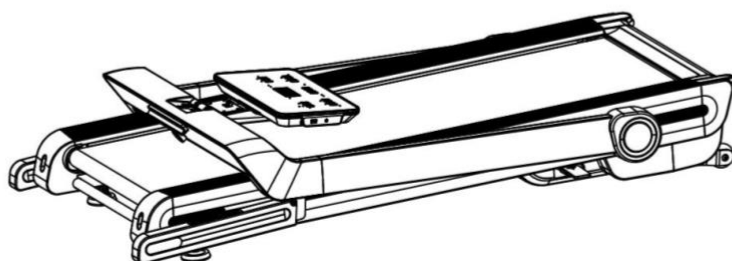
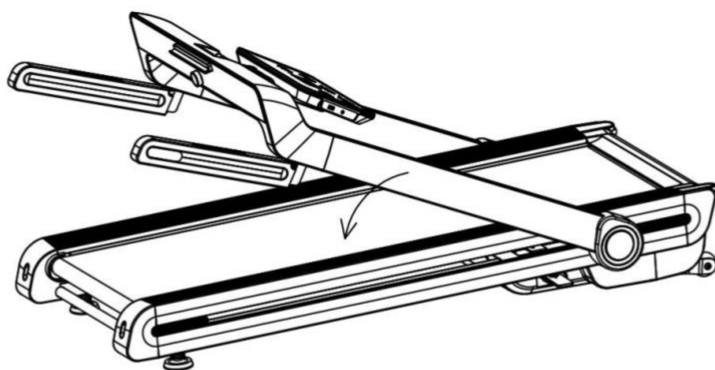
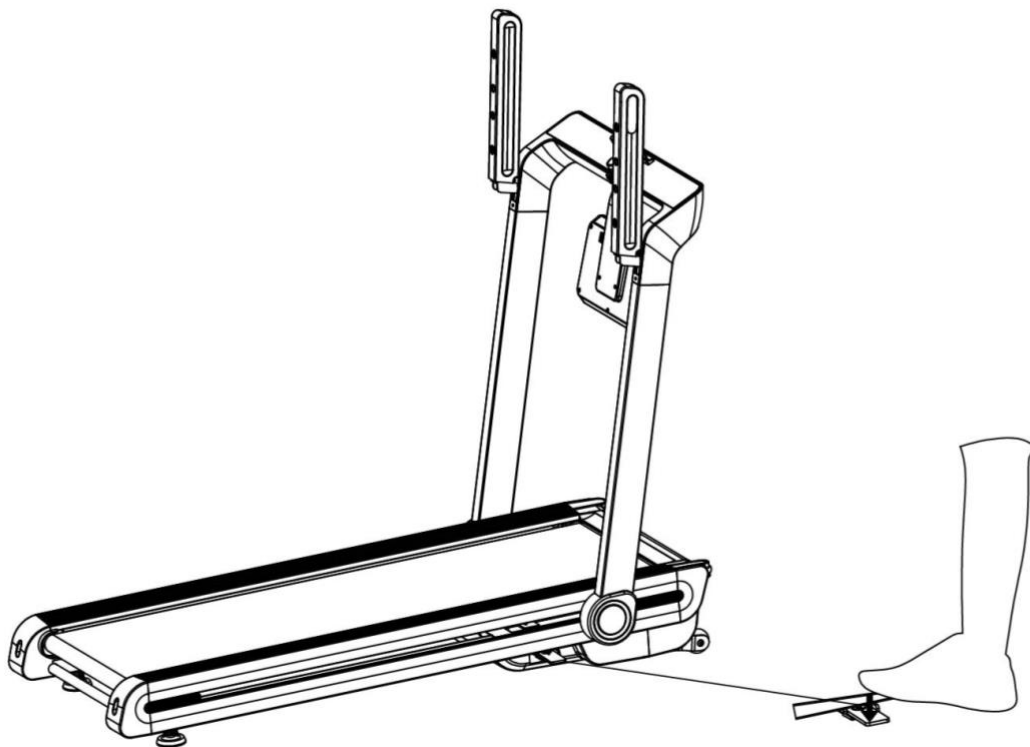

C-3

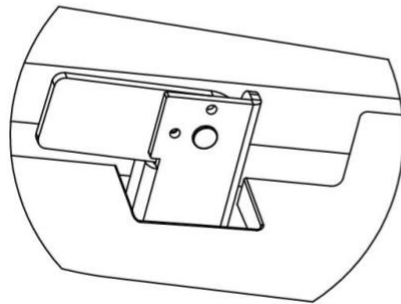
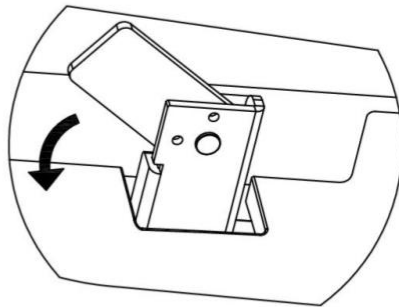
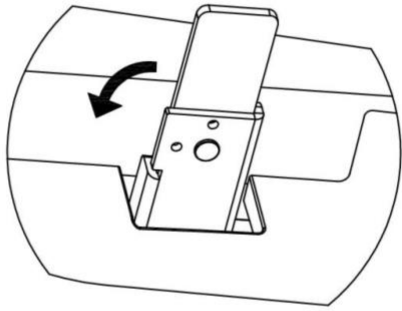

C-4

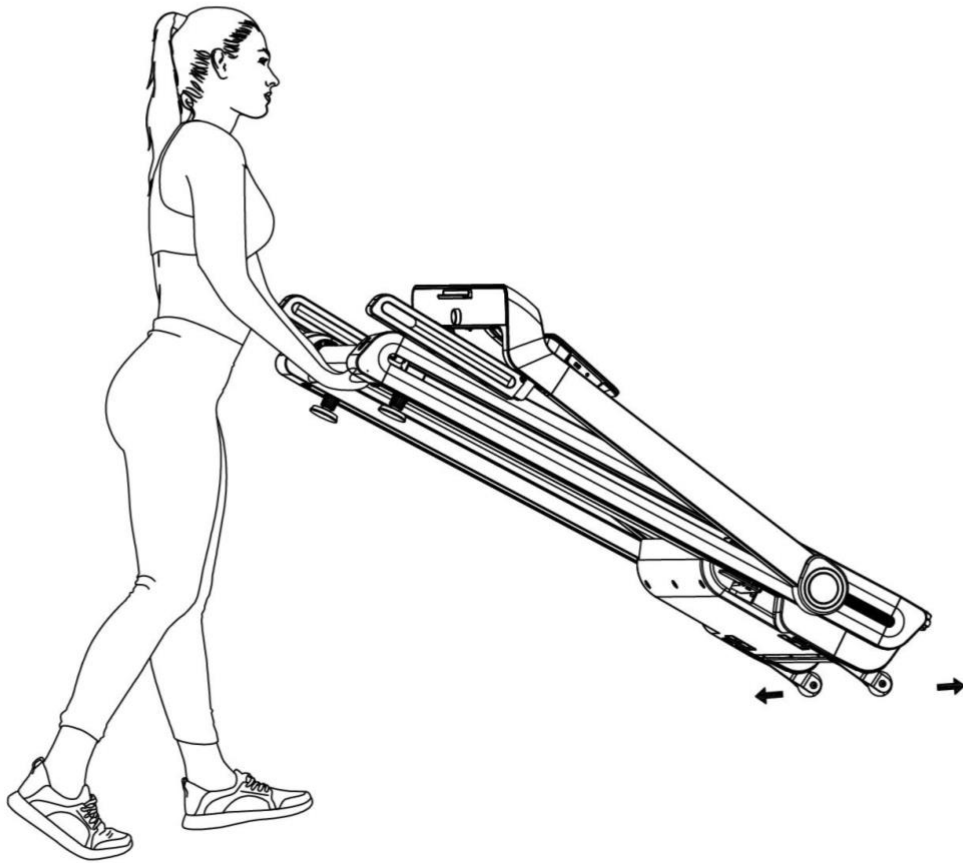
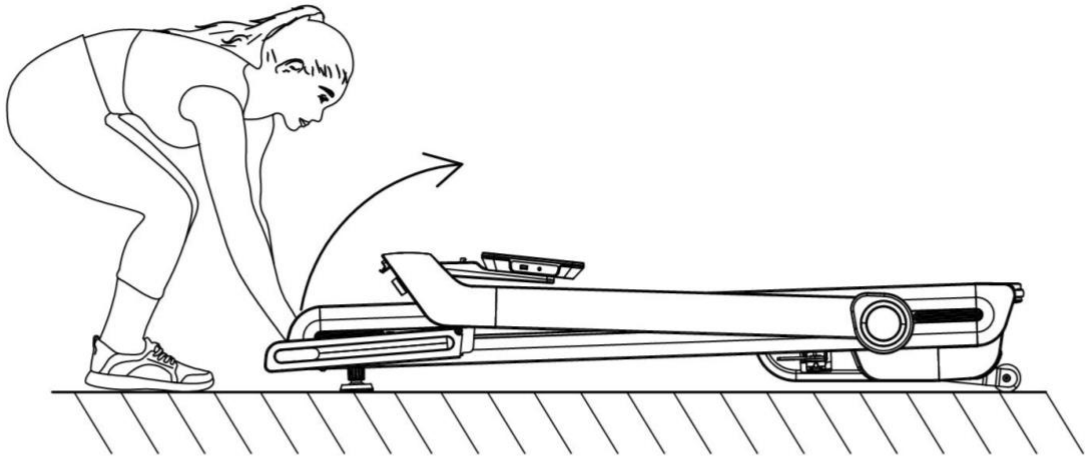

C-5

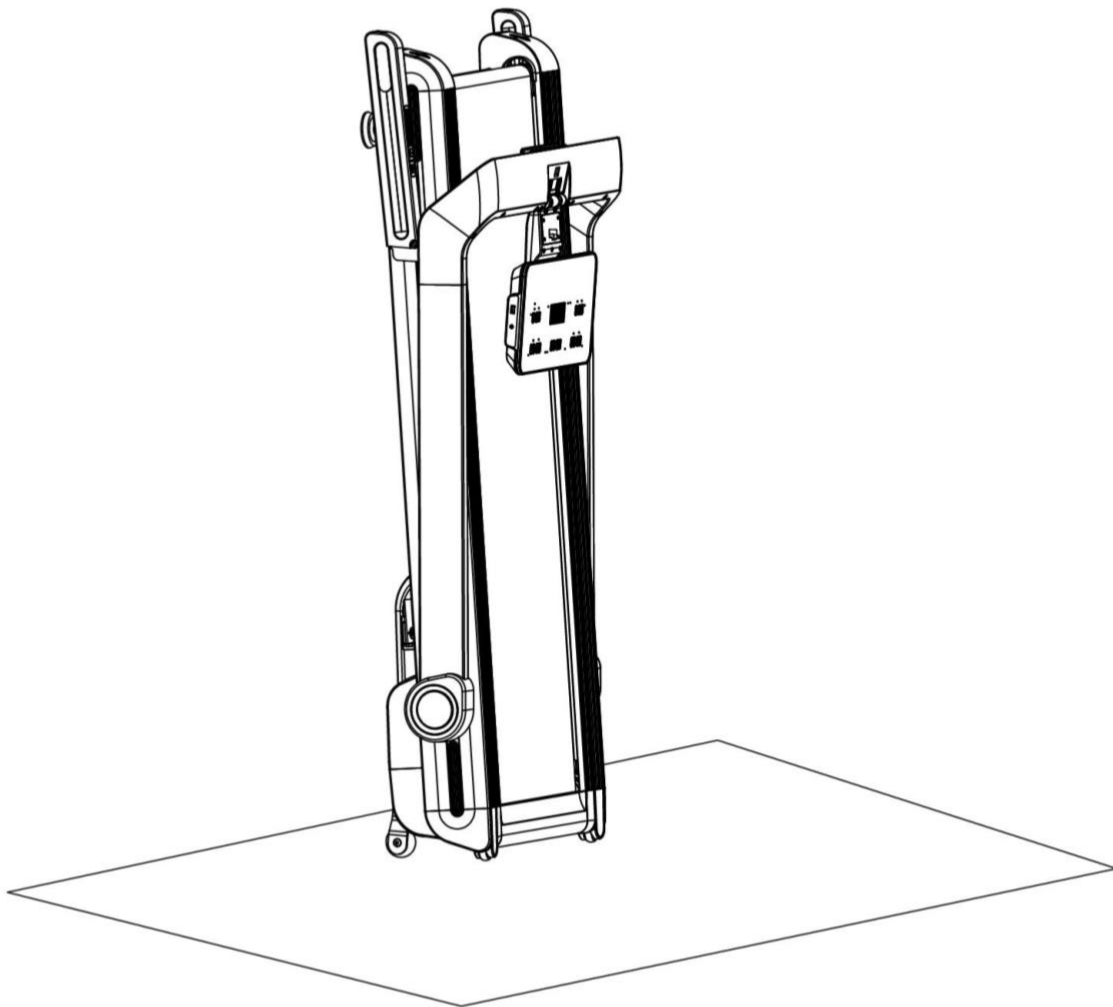

OPERATION GUIDE

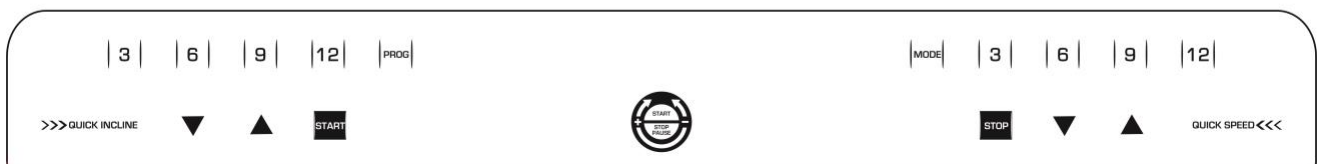
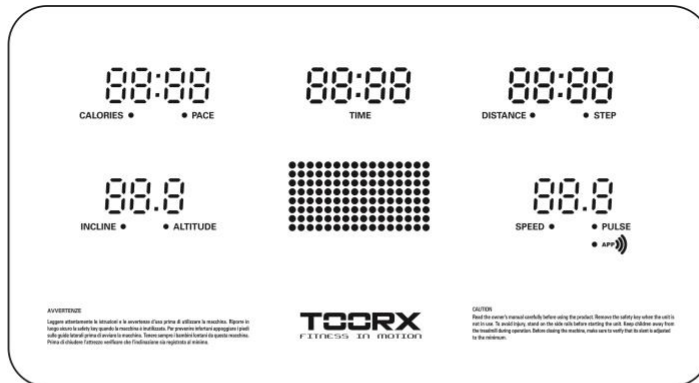

BUTTON FUNCTIONS:

1. INSTANT INCLINE: Press 3-6-9-12 to choose incline quickly.
2. INCLINE-/INCLINE+: Press triangle button to adjust the incline.
3. PROG: Press this button to choose between 24 programs, 4 user, 4 HRC and body fat.
4. START: Press this button to start the machine at any time.
5. START/PAUSE/STOP: Press the middle knob button to start/pause/stop the machine, turn left/right to adjust the speed.
 - Under program selecting state, turn the knob button to choose program(P01-P24, U01-U04, HP1-HP4, FAT), press the knob button to enter into the program, adjust the parameters, then short press to start the machine or long press to go back to standby mold.
 - Under manual mode, press the knob button, the treadmill will be started after 3seconds countdown;
 - Under pause mode, quick press this knob button to re-start the machine;
 - Under pause mode, long press this knob button for 3 seconds, the machine will be stop and reset;
 - Under standby mode, turn the knob clockwise to speed up the machine, and turn the knob counterclockwise to slow down the machine.
6. MODE: Press this button to choose between time, distance, calories workout targets.
7. STOP: Press this button to pause or stop the machine.
8. INSTANT SPEED: Press 3-6-9-12 to choose speed quickly.
9. SPEED-/SPEED+: Press this button to adjust the speed.

MEDIA HUB:

1. MP3 INPUT: Insert MP3 cable to display the music from device.

COMPUTER FUNCTIONS:

1. CALORIES/PACE: Display the calories has consumed, PACE is to display the time you walked 1 kilometer.

2. TIME: Display the time has run.

3. DISTANCE/STEP: Display the distance has run, STEP is to display the total steps you have walked.

4. INCLINE/ALTITUDE: Display current incline. Press INCLINE triangle button to adjust the incline of the machine. ALTITUDE is to display the altitude.

5. SPEED: Display current speed. Press SPEED+/- to adjust the speed of the machine.

6. PULSE: Display user's heart rate, this data is just for reference, can not be regarded as medical use. Hold the hand pulse sensor by both hands, the console will show user's pulse value after about 5 seconds.

7. MODE: Press Mode button to enter TIME, DISTANCE, CALORIES.

-From standby mode, press Mode button, the corresponding light of TIME, DISTANCE, CALORIES will shown on , select between TIME, DISTANCE, CALORIES.

-Press SPEED+/- or INCLINE triangle button or turn the knob to set the workout target value.

-Press START button, treadmill will run after 3 seconds.

-Press SPEED+/- to adjust the speed .

-Press INCLINE triangle button to adjust the incline .

8. PROGRAMS: Press this button to choose between 24 programs, 4 user, 4 HRC and body fat.

8.1 Set of 24 build-in programs: From standby mode, press PROG button, console will show 24 programs, select between 24 programs.

-Press SPEED+/- or INCLINE triangle button or turn the knob button to set the workout target value.

-Each program can be divided into 10 sections; machine will beep 3 times when starting a new section.

-Press SPEED+/- or turn the knob button or INCLINE triangle button to change the speed and incline during each section.

-Machine will beep 3 times and stop when the program is finished.

8.2 Set of 4 user programs: From standby mode, press PROG button until you see U1,U2,U3,U4;

- Press SPEED+/- or INCLINE triangle button or turn the knob button to set the time.

- Press MODE button to confirm and enter next section, repeat until you finish the setting of all 30 sections.

- Press SPEED+/- or INCLINE triangle button or turn the knob to change the speed or incline.

- Set the running time and press START to begin.

8.3 Set of 4 heart rate programs: From standby mode, press PROG button until you see HP1,HP2,HP3,HP4; To use this function, you need a chest belt. The chest belt need to close to the skin of your chest.

-Max speed is 10.0km/h.

-Press MODE button, the window will show default age of 30, pressing INCLINE triangle button or SPEED+/- or turn the knob button to choose your age, heart rate value and time setting.

-Set the running time and press START to begin.

-Under heart rate program, you can press SPEED+/- or INCLINE triangle button or turn the knob button to change speed and incline, but the system will adjust speed and incline to reach your target heart rate value.

8.4 Set of body fat test: From standby mode, press PROG button until you get to FAT.

-Press Mode button to enter information.

Set value with SPEED+/- or the knob button from F-1 to F-4(F-1 GENDER, F-2 AGE, F-3 HEIGHT, F-4 WEIGHT)

-Press Mode button to enter F-5(F—5 BODY FAT TEST), hold hands on the hand pulse sensor, the console will display your body fat value after 3 seconds.

-The body fat value is intended as a guide, and is not medical data:

F-1	Gender	01 male	02 female
F-2	Age	10-99	
F-3	Height	100-200CM	
F-4	Weight	20-150KG	
F-5	FAT	≤19	Under weight
	FAT	=(20---25)	Normal weight
	FAT	=(26---29)	Overweight
	FAT	≥30	Obesity

LUBRICATION REMIND FUNCTION

This machine has lubrication remind function. After every total running distance of 300km , treadmill screen will remind with lubrication. Please read the user’s manual first, and add the oil to the middle part of running board.

SAFETY LOCK FUNCTION:

Under any mode, if you pull away the safety key, the machine will stop. The window will show “---” with reminding sound. The machine cannot work until safety key is inserted back.

ENERGY SAVING FUNCITON

To reduce energy consumption, this treadmill will enter into sleeping mode if without any operation for 10 minutes. The screen will give reminding before enter into sleeping mode. Once machine enter sleeping mode, please take off safety key and insert again to awaken the system.

POWER ON (I) AND POWER OFF (O)

Switch off the power: You can switch off the power to stop the treadmill, this will not cause

MAINTENANCE & CARE

General cleaning will help prolong the life and performance of your treadmill. Keep the unit clean and maintained by dusting the components on a regular basis. Clean both sides of the running belt to prevent dust from accumulating underneath the belt. Keep your running shoes clean so that dirt from your shoes does not wear out the running board and belt. Clean the surface of the running belt with a clean damp cloth.

- To better maintain the treadmill and prolong its life it is suggested that the machine be powered off for 10 minutes every 2 hours and fully powered off whenever not in use.
- A loose Running Belt will result in the runner sliding off when running, while too tight of a Running Belt will result in decrease to the motors performance and also create more friction between the roller and running belts. The most suitable tightness for the belts is pulled out 50-75mm from the Running Board.

CENTERING THE RUNNING BELT:

Place the treadmill on level ground and set it at 6-8kph to check if the Running Belt drifts.

1. If the **Running Belt** moves to the **right**, turn the adjusting bolt on the right side $\frac{1}{4}$ turn *clockwise*, then turn the left adjustment bolt $\frac{1}{4}$ turn *counter-clockwise*. If the belt does not move, repeat this step until it centers. Refer to figure A.

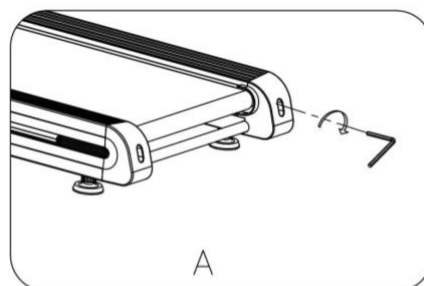

2. If the **Running Belt** moves to the **left**, turn the adjusting bolts on the left side $\frac{1}{4}$ of a turn *clockwise*, then turn the right adjustment bolt $\frac{1}{4}$ turn *counter-clockwise*. If the belt does not move, repeat this step until it centers. Refer to figure B.

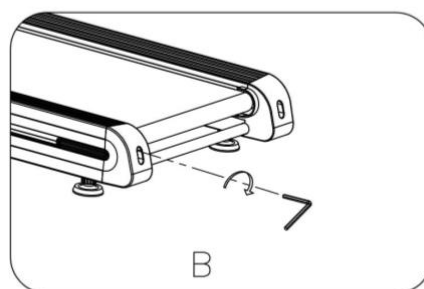

3. Over time the **Running Belt** will **loosen**. To tighten the belt turn the Left & Right side adjustment bolts one full turn clockwise, check the tension of the belt. Continue this process until belt is at the correct tension. Make sure to adjust both sides equally to ensure correct belt alignment. Refer to figure C.

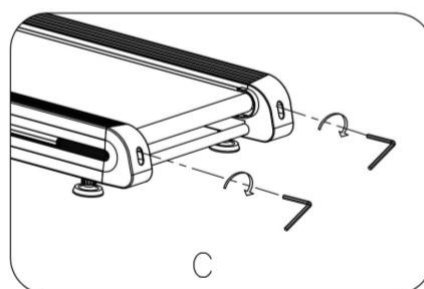

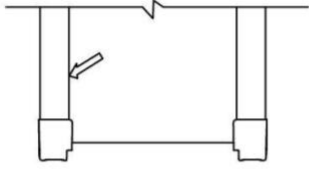

✘

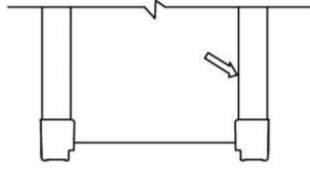

✘

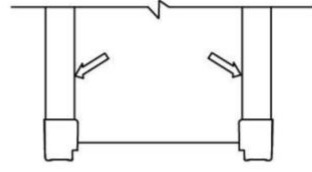

✔

EXPLODED DRAWING

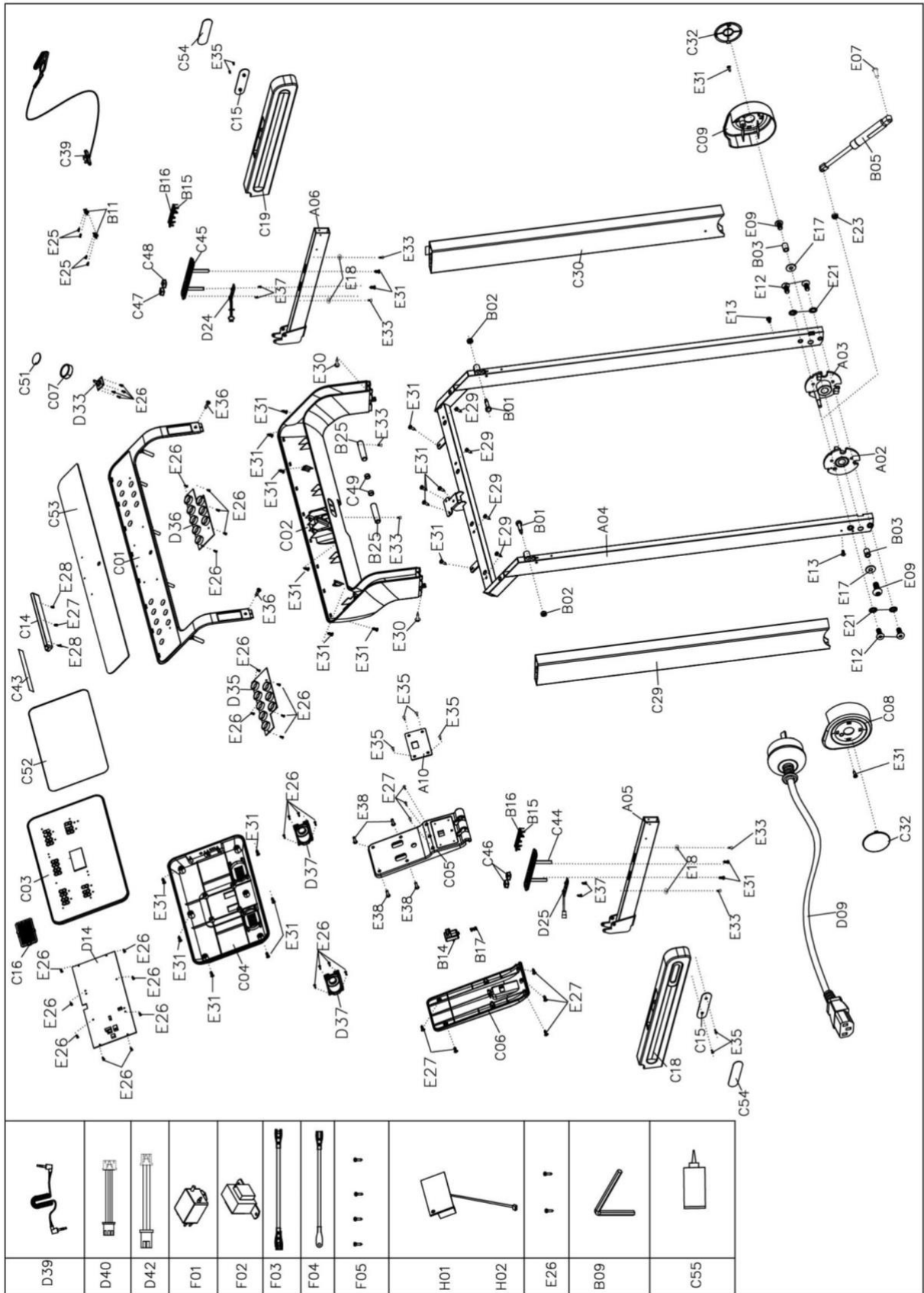

D39	
D40	
D42	
F01	
F02	
F03	
F04	
F05	
H01	
H02	
E26	
B09	
C55	

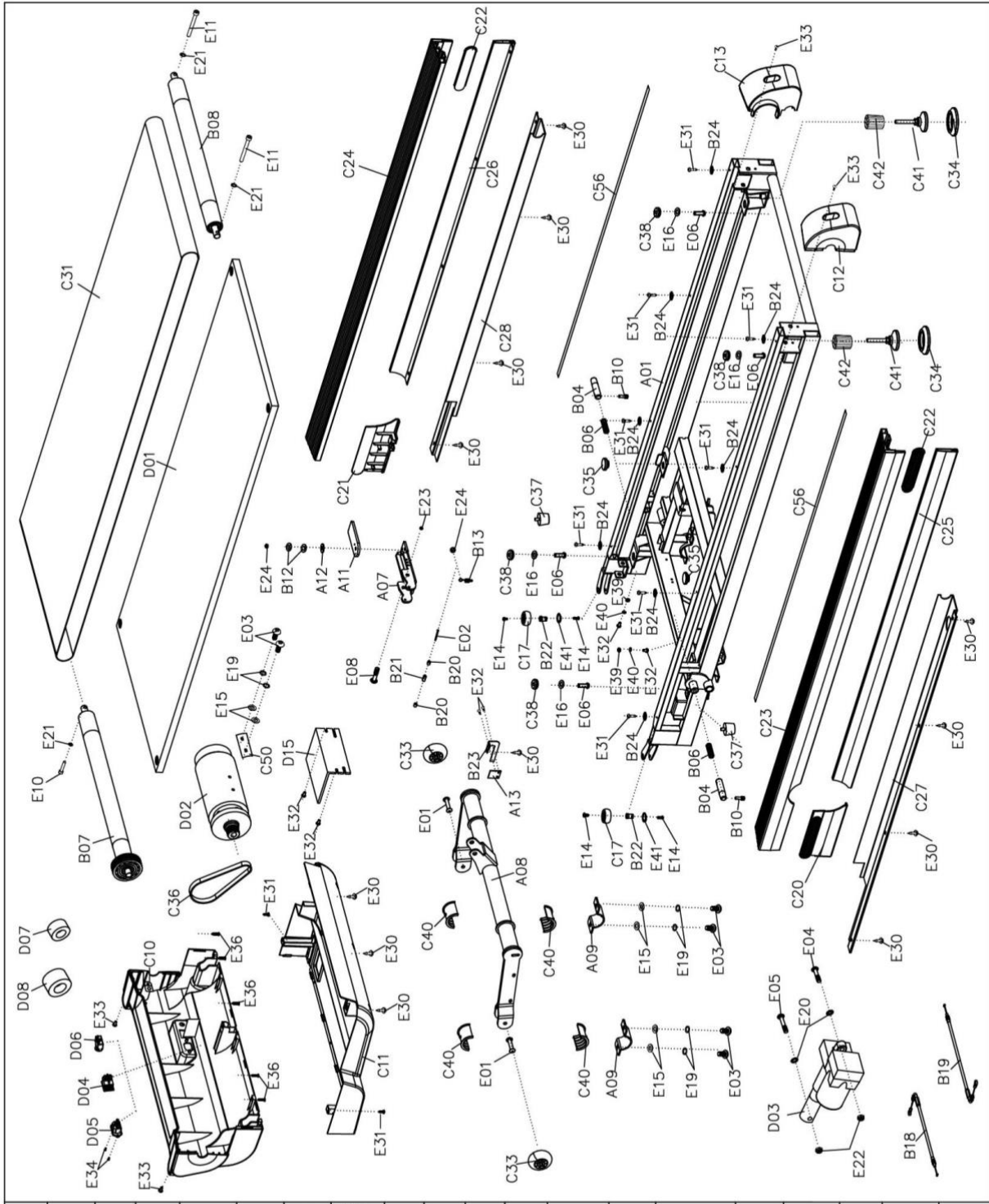

D10	
D11	
D12	
D13	
D16	
D17	
D18	
D19	
D20	
D21	
D22	
D23	
D26	
D27	
D28	
D29	
D30	
D31	
D32	
D34	

PARTS LIST

No.	Part description	Remark	QTY	No.	Part description	Remark	QTY
A01	Main frame		1	C55	Silicone oil		1
A02	Left upright turning bracket		1	C56	EVA mat	1300*15*2.0	2
A03	Right upright turning bracket		1	D01	Running board		1
A04	Console base bracket		1	D02	DC motor		1
A05	Left handrail bracket		1	D03	Incline motor		1
A06	Right handrail bracket		1	D04	Square Switch		1
A07	Folding pedal bracket		1	D05	Power socket		1
A08	Incline bracket		1	D06	Overload protector		1
A09	Turning lock plate		2	D07	Magnetic ring		1
A10	Reinforced square plate		1	D08	Magnetic core		1
A11	Folding pedal		1	D09	Power wire		1
A12	Anti-turning washer		1	D10	AC single wire	Wire length 200mm	1
A13	Sounding Board		1	D11	AC single wire	Wire length 350mm	2
B01	Handrail axis	φ14*39	2	D12	AC single wire	Wire length 350mm	2
B02	Handrail turning bolt	φ14*6	2	D13	Grounding wire	Wire length 350mm	1
B03	Bushing	φ14*20.5	2	D14	Console		1
B04	Locking pin	φ15*65	2	D15	Control board		1
B05	Cylinder		1	D16	Top signal wire	Wire length 450mm	1
B06	Locking pin spring	φ12*41	2	D17	Middle signal wire 1	Wire length 600mm	1
B07	Front roller		1	D18	Middle signal wire 2	Wire length 1100mm	1
B08	Back roller		1	D19	Bottom signal wire	Wire length 500mm	1
B09	6# Allen wrench		1	D20	Instant speed top signal wire	Wire length 450mm	1
B10	Pull pin	φ9*23.5	2	D21	Instant incline top signal wire	Wire length 450mm	1
B11	Safety key spring		2	D22	Instant speed top signal wire	Wire length 650mm	1
B12	Saucer washer	φ6.0	2	D23	Instant incline top signal wire	Wire length 650mm	1
B13	Elastic string	φ7*37	1	D24	Instant speed bottom signal wire	Wire length 300mm	1
B14	Sliding buckle	39*24*35	1	D25	Instant incline bottom signal wire	Wire length 300mm	1
B15	Pulse plate - L		2	D26	Hand pulse top signal wire		1
B16	Pulse plate - R		2	D27	Hand pulse middle signal wire		2
B17	Spring plate 2	φ0.8*φ8*15	1	D28	Hand pulse bottom signal wire		2
B18	Triming line 2	410	1	D29	Safety switch top signal wire		1
B19	Triming line	550	1	D30	Safety switch bottom signal wire		1
B20	Limit bushing - Short	φ7*7.5	2	D31	Button board wire 1		1
B21	Limit bushing - Long	φ7*15	1	D32	Button board wire 2		1

B22	Top roller axis	φ12*16.6	2	D33	Turning knob board		1
B23	Spring seat	δ1.0	1	D34	Five-core wire	Wire length 150mm	1
B24	Side rail washer	φ20*δ1.5	8	D35	Left button board		1
B25	Spacer pin	φ10*36.5	2	D36	Right button board		1
C01	Console top cover		1	D37	Speaker wire		2
C02	Console bottom cover		1	E01	bottom roller bolt assembly	φ8*36.5	2
C03	Panel top cover		1	E02	Bolt	M5*50	1
C04	Panel bottom cover		1	E03	Bolt	M8*20	6
C05	Panel bracket top cover		1	E04	Bolt	M10*55	1
C06	Panel bracket bottom cover		1	E05	Bolt	M10*40	1
C07	Turning knob		1	E06	Bolt	M8*24	4
C08	Left upright tube side cover		1	E07	Bolt	M8*20	1
C09	Right upright tube side cover		1	E08	Bolt	M8*60	1
C10	Motor front cover		1	E09	Bolt	M10*35	2
C11	Motor bottom cover		1	E10	Bolt	M8*50	1
C12	Rear cover - L		1	E11	Bolt	M8*65	2
C13	Rear cover - R		1	E12	Bolt	M8*32	4
C14	Ipad holder		1	E13	Bolt	M6*15	2
C15	Handrail label holder		2	E14	Bolt	M5*10	4
C16	Matrix plate		1	E15	Flat washer	8	6
C17	Small roller bracket		2	E16	Big washer	φ8*φ22*2.0	4
C18	Handrail foam- L		1	E17	Big washer	φ10	2
C19	Handrail foam- R		1	E18	Big washer	φ5	4
C20	Left front cover		1	E19	Spring washer	8	6
C21	Right front cover		1	E20	Lock washer	10	2
C22	Back cover		2	E21	Lock washer	8	7
C23	Left top side rail		1	E22	Nut	M10	2
C24	Right top side rail		1	E23	Nut	M8	2
C25	Left bottom side rail		1	E24	Nut	M6	2
C26	Right bottom side rail		1	E25	Screw	ST2.5*6	4
C27	Left bottom rail		1	E26	Screw	ST2.9*6	32
C28	Right bottom rail		1	E27	Screw	ST2.9*8	9
C29	Left upright cover		1	E28	Screw	ST2.9*12	2
C30	Right upright cover		1	E29	Screw	ST4.2*35	4
C31	Running belt		1	E30	Screw	ST4.2*12	14
C32	Small cover		2	E31	Screw	ST4.2*12	33
C33	Moving wheel		2	E32	Bolt	M5*8	4
C34	Tube foot cover		2	E33	Bolt	M5*12	10
C35	Cushion		2	E34	Screw	ST2.9*8	2
C36	Motor belt		1	E35	Screw	ST2.9*12	8
C37	Cone cushion		2	E36	Screw	ST4.2*12	7
C38	Running board pad		4	E37	Screw	ST2.5*6	4
C39	Safety key		1	E38	Bolt	M5*16	4

C40	Nylon turning bushing		4	E39	Lock washer	5	2
C41	Universal pad 2		2	E40	Spring washer	5	2
C42	Foot pad sleeve 1		2	E41	Axis elastic collar	10	2
C43	Stopper pad		1	F01	Filter		1
C44	Instant incline base		1	F02	Inductance		1
C45	Instant speed base		1	F03	Single wire	Wire length 500mm	1
C46	Button		2	F04	Ground wire	Wire length 350mm	1
C47	Button+		1	F05	Screw	ST4.2*12	4
C48	Button-		1	G01	Wireless receiver		1
C49	Anti-rotating washer		2	G02	HRC connecting wire		1
C50	Motor rubber washer		1	G03	Screw	ST2.9*6.0	4
C51	Turning knob overlay		1	H01	Bluetooth module		1
C52	Console panel overlay		1	H02	Bluetooth connecting wire		1
C53	Button overlay		1	H03	Screw	ST2.9*6.0	1
C54	Handrail label		2				



GARLANDO SPA
Via Regione Piemonte, 32 - Zona Industriale D1
15068 - Pozzolo Formigaro (AL) - Italy
www.toorx.it - info@toorx.it